

# CELL130

- Designed to fit 32mm (1 1/4") to 35mm (1 3/8") truss tubes
- Precision extruded high tensile aluminium alloy
- Compatible with M222 truss series
- CE certified
- Polished surface with laser markings
- Rated with SF 8:1 (kg) DGUV17/BGV C1 (SWL1)
- Rated with SF 4:1 (kg) 2006/42/EC (SWL2)
- Interchangeable M10 screw ensures flexible attachment points
- Powder coated versions available on request
- Black anodized versions available

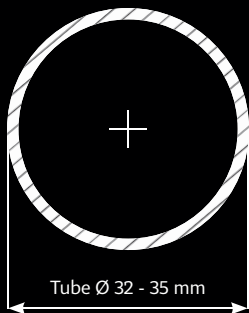



**CELL131 / CELL131|anodized**

Basic clamp

kg	lbs	SWL1	SWL2	Weight	Tube Ø
		160 (353)	330 (728)	0.10 (0.20)	32-35 mm (1.26"-1.38")

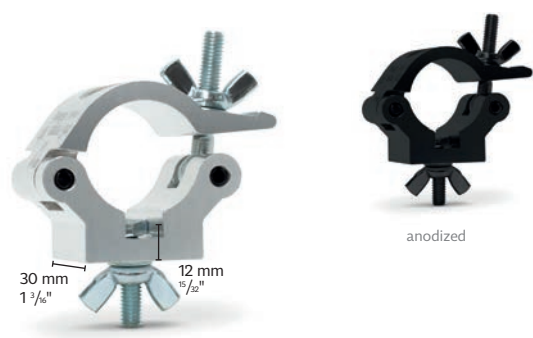
Basic Clamp can be used for most applications.

**CELL132 / CELL132|anodized**

Clamp with bolt and wingnut

kg	lbs	SWL1	SWL2	Weight	Tube Ø
		160 (353)	330 (728)	0.25 (0.33)	32-35 mm (1.26"-1.38")

Clamp supplied with M10 x 30 bolt and wingnut.

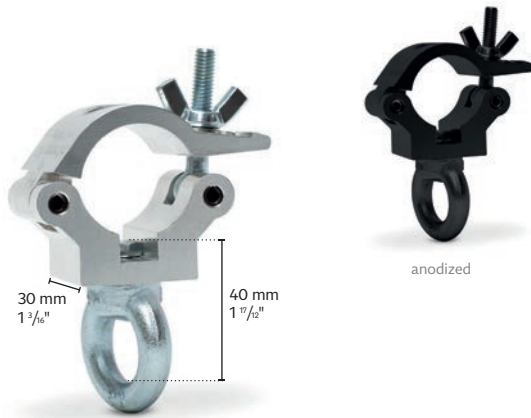
**CELL133 / CELL133|anodized**

Clamp with lifting eye

kg	lbs	SWL1	SWL2	Weight	Tube Ø
		160 (353)	330 (728)	0.70 (1.54)	32-35 mm (1.26"-1.38")

Clamp with lifting eye

**CELL134 / CELL134|anodized**

Swivel coupler

kg	lbs	SWL1	SWL2	Weight	Tube Ø
		160 (353)	330 (728)	0.80 (1.76)	32-35 mm (1.26"-1.38")

Set of two clamps free to rotate 360° for connection of two tubes.

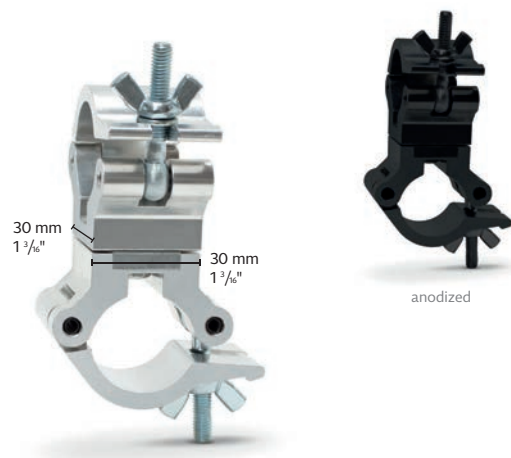
**CELL135 / CELL135|anodized**

90° fixed coupler

kg	lbs	SWL1	SWL2	Weight	Tube Ø
		160 (353)	330 (728)	0.80 (1.76)	32-35 mm (1.26"-1.38")

90° fixed coupler

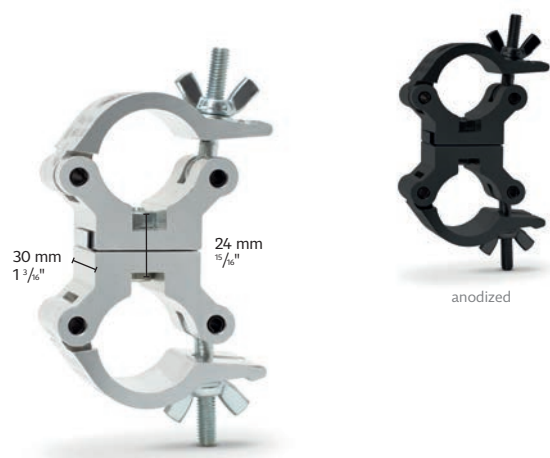
**CELL136 / CELL136|anodized**

Parallel coupler

kg	lbs	SWL1	SWL2	Weight	Tube Ø
		160 (353)	330 (728)	0.80 (1.76)	32-35 mm (1.26"-1.38")

Set of two clamps fixed parallel to each other for connection of two tubes.



anodized



**CELL143 / CELL143|anodized**

Boom Arm

	L1	L2	L3	Tube Ø
mm	250	500	750	32-35
in	39.37"	19.69"	29.52"	1.26"-1.38"

Tube 32x1.5mm also available in custom lengths.



