





**CELL501 / CELL501|anodized**

Basic clamp

	SWL1	SWL2	Weight	Tube Ø
kg	230 (507)	460 (1014)	0.14 (0.30)	48-51 mm (1.89"-2")
lbs				

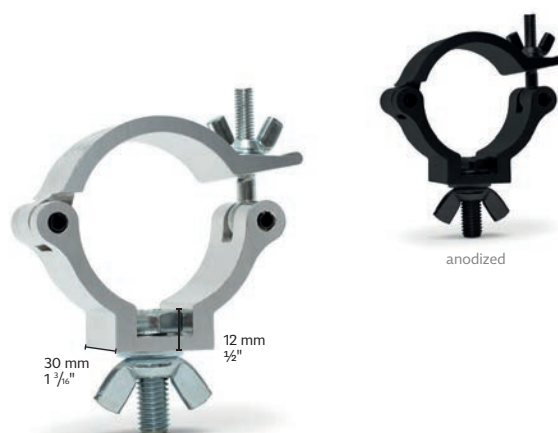
Basic clamp can be used for lightweight applications.

**CELL502 / CELL502|anodized**

Clamp with bolt and wingnut

	SWL1	SWL2	Weight	Tube Ø
kg	230 (507)	460 (1014)	0.22 (0.47)	48-51 mm (1.89"-2")
lbs				

Clamp supplied with M10 x 30 bolt and wingnut.

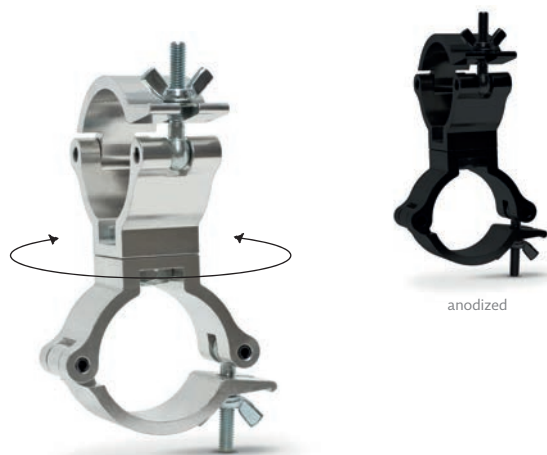
**CELL504 / CELL504|anodized**

Swivel coupler

	SWL1	SWL2	Weight	Tube Ø
kg	230 (507)	460 (1014)	0.27 (0.60)	48-51 mm (1.89"-2")
lbs				

Set of two clamps free to rotate 360° for connection of two tubes.

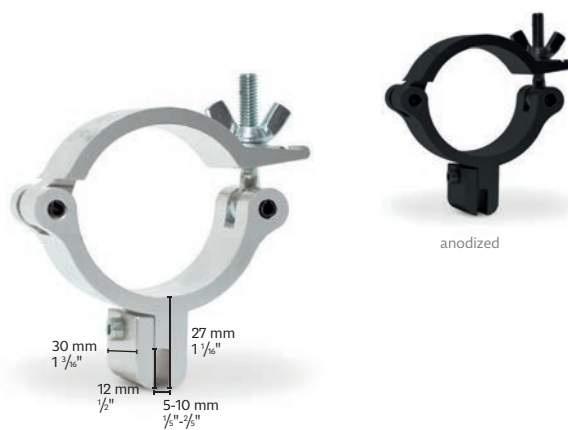
**CELL511 / CELL511|anodized**

Panel Clamp

	SWL	Weight	Tube Ø
kg	55 (121)	0.22 (0.47)	48-51 mm (1.89"-2")
lbs			

Panel thickness range 5-10 mm (0.19"-0.39")

